

DATASHEET

PRODUCT **MultiLayer chip Varistor**

JMV-S Series

JMV-C Series

JMV-E Series

JMV-N Series

SERIES

JMV-B Series

PART NO.

ISSUE DATE

2023/6/12

REVISION DATE

2023/6/12

REFERENCE NO.

RoHS COMPLIANCE ITEM

Halogen Free

Disclaimer:

- This datasheet is downloaded from the Website of Joyin Co., Ltd, and Joyin Co., Ltd. reserves all rights for modification content without further notification.
- All product, specification and data are subject to change without notice.
- Joyin Co., Ltd, its affiliates, agents, employees, and all persons acting on its or their behalf, hereby disclaim any and all liability for any errors, inaccuracies or incompleteness contained in any product related information, including but not limited to product specifications, datasheets, pictures and/or graphics.
- Joyin Co., Ltd makes no warranty, representation or guarantee regarding the suitability of the products for any particular purpose or the continuing production of any product. It is the customer's responsibility to validate that a particular product is suitable for use in a particular application.
- To the maximum extent permitted by applicable law, Joyin Co., Ltd disclaims (i) any and all liability arising out of the application or use of any product, (ii) any and all liability, including without limitation special, consequential or incidental damages, and (iii) any and all implied warranties, including warranties of fitness for particular purpose, non-infringement and merchantability.
- If you have any questions, please contact our sales staff.

INTRODUCTION



Joyin's metal oxide based chip varistor (JMV) are used for transient voltage suppression. JMV has non-linear voltage current behavior which is similar to Zener Diode.

久尹的金屬氧化物電阻（JMV）用於抵制瞬間電壓，JMV 具有與二極體相似的非線性電壓電流特性。

Since each grain in JMV exhibits small p-n-p junction, it has much better electrical reliability than Zener Diode. Furthermore, JMV also exhibits better electrical properties, such as excellent clamping voltage and low leakage current.

由於 JMV 中的每一晶粒都具有細小的 p-n-p 結，因此比二極體具有更好且可靠的電性。此外，JMV 還具有更好的電氣特性，例如優良的抑制電壓和低漏電流。

ESD Protection Introduction

ESD (Electrostatic Discharge)

The static to damage electronic devices is a problem not easy to resolve. Once the electronic devices are damaged by ESD, it will usually appear abnormal situation. If it's not a serious problem, it needs to reset for equipment. If it's a serious damage, the products will be broken.

Static electricity is ubiquitous, mostly caused by human. For example, in the manufacturing process of electronic components, product assembly, transportation, storage environment, etc.. In the dry environment, the air flow causes molecules to rub against each other, which also leads to more significant electrostatic effect.

防靜電保護介紹

靜電放電

ESD 對電子產品的傷害一直是不易解決的問題。一般電子產品受到 ESD 作用時會出現不穩定的狀況，輕微的只需要重開機即可，嚴重可能導致電子產品內的電子元件毀損。靜電無所不在，多是人為造成，例如：電子元件製造過程中、產品組裝、搬運過程、儲存環境等。在乾燥的環境下加上空氣的流動造成分子互相摩擦，也會導致靜電作用更加顯著。

ADVANTAGE

- Lead free plating termination provided
- Insulator over coat keeps excellent low and stable leakage current

CONSTRUCTION

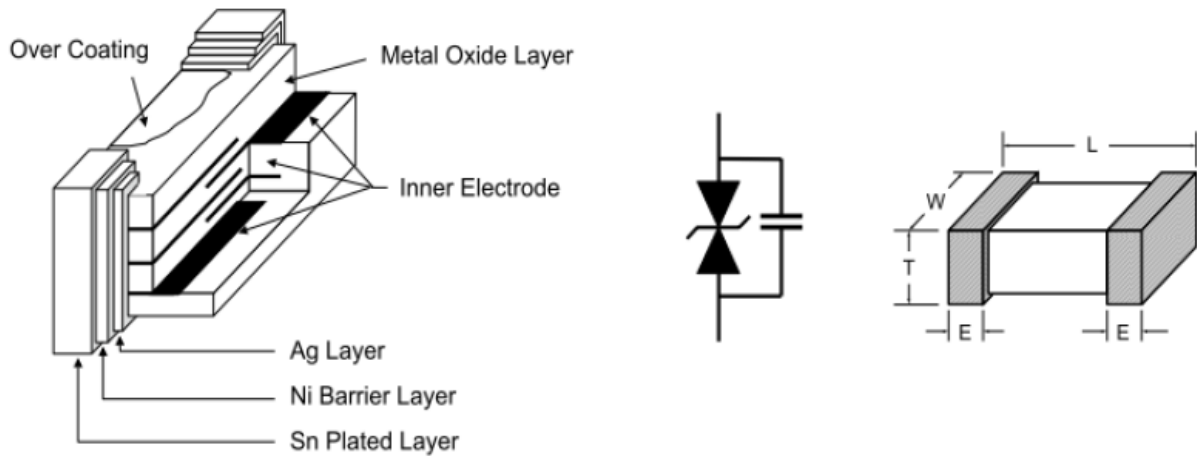

PRODUCT SERIES

PN Series	SIZE								Vdc (V)							Varistor Voltage (V)												
	0201	0402	0603	0805	1206	1210	1812	2220	5.5	12	18	26	42	65	85	7.6	8	9	11	12	15	18	21	22	25	75	90	120
JMV-S series	■	■	■	■	■	■	■	■	■	■	■	■	■	■	■	■	■	■	■	■	■	■	■	■	■	■	■	■
JMV-C series		■	■						■	■	■	■	■			■	■	■	■	■	■	■	■	■	■	■	■	■
JMV-E series		■	■						■	■							■	■	■		■	■	■		■			

JMV-S Series

FEATURES

- SMD type zinc oxide based ceramic chip
- Quick response time (<1ns)
- High transient current capability
- Meet IEC 61000-4-2 standard
- Meet IEC 61000-4-5 standard
- Compact size for EIA
0201/0402/0603/0805/1206/1210/1812/2220

APPLICATIONS

Mother Board and Notebook, Cellular Phone, PDA, handheld device, DSC, DV, Scanner, and Set-Top Box etc.

EXPLANATION OF PART NUMBER

JMV	0201	S	5R5	T	330	XXG
①	②	③	④	⑤	⑥	⑦
① Joyin Multilayer Varistor			⑤ Tape on reel			
② Chip size			⑥ Optional Suffix			
③ Surge Protection and ESD Protection			⑦ Internal ID			
④ Max DC working voltage						

DIMENSION

unit:mm

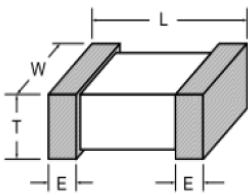

Size(EIA)	L	W	T	E
0201	0.60±0.05	0.30±0.05	0.30±0.05	0.20±0.10
0402	1.00±0.10	0.50±0.10	0.34±0.10	0.20±0.15
0603	1.60±0.10	0.85±0.15	0.51±0.05	0.30±0.20
0805	2.00±0.20	1.25±0.15	0.90±0.10	0.50±0.25
1206	3.20±0.30	1.60±0.20	1.7 max	0.50±0.25
1210	3.20±0.30	2.50±0.25	1.7 max	0.50±0.25
1812	4.50±0.40	3.20±0.30	2.5 max	0.60±0.30
2220	5.70±0.40	5.20±0.40	4.0 max	1.4 max

SOLDER LAND INFORMATION

unit:mm

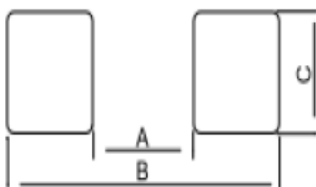

Size(EIA)	A	B	C
0201	0.30	0.80	0.30
0402	0.50	1.70	0.50
0603	0.50	2.50	0.76
0805	1.10	3.50	1.20
1206	2.20	4.24	1.65
1210	2.20	4.50	2.80
1812	3.00	6.00	3.60
2220	4.20	7.20	5.50

STANDARD PACKING

Size (EIA)	0201	0402	0603	0805	1206	1210	1812	2220
Quantity (pcs/reel)	15,000	10,000	4,000	4,000	3,000	2,000	1,000	1,000

SPECIFICATION

	Working Voltage		Varistor Voltage		Clamping Voltage	Capacitance
Symbol	V_{RMS}	V_{DC}	V_V	V_V	V_C	C_P
Units	Volts	Volts (Max.)	Volts		Volts (Max.)	pF (Typical)
Test Condition		< 10 μ A	1mA DC		1A @ 8/20 μ s	1MHz
JMV0201S5R5T100XXG	4	5.5	11	± 3	31	10
JMV0201S5R5T330XXG	4	5.5	11	± 3	28	33
JMV0201S5R5T470XXG	4	5.5	11	± 3	26	47
JMV0201S5R5T640XXG	4	5.5	11	± 3	26	64
JMV0201S070T2R5XXG	5	7	40	± 10	90	2.5
JMV0201S120T2R5XXG	8	12	40	± 10	90	2.5

	Working Voltage		Varistor Voltage	Clamping Voltage	Capacitance	Peak Current	Transient Energy
Symbol	V_{RMS}	V_{DC}	V_V	V_C	C_P	i_{max}	W_{max}
Units	Volts	Volts (Max.)	Volts	Volts (Max.)	pF (Typical)	Amps (Max.)	Joules (Max.)
Test Condition		< 10 μ A	1mA DC	1A @ 8/20 μ s	1MHz	8/20 μ s	10/1000 μ s
JMV0402S5R5T271XXG	4	5.5	8 ~ 18	24	270	20	0.05
JMV0402S090T131XXG	7	9	11.5 ~ 21.5	41	130	20	0.05
JMV0402S180T850XXG	14	18	23 ~ 33	54	85	20	0.05
JMV0402S200T350XXG	17	20	32 ~ 43	70	35	20	0.05
JMV0603S5R5T271XXG	4	5.5	8 ~ 18	24	270	30	0.1
JMV0603S090T211XXG	6	9	11.5 ~ 21.5	41	210	30	0.1
JMV0603S180T151XXG	14	18	23 ~ 33	54	150	30	0.1
JMV0603S260T101XXG	20	26	32 ~ 42	70	100	30	0.1

	Working Voltage		Varistor Voltage	Clamping Voltage	Capacitance
Symbol	V_{RMS}	V_{DC}	V_V	V_C	C_P
Units	Volts	Volts (Max.)	Volts	Volts (Max.)	pF (Typical)
Test Condition		< 10 μ A	1mA DC	1A @ 8/20 μ s	1MHz
JMV0402S120T070XXG	9	12	25 ~ 40	110	7
JMV0402S120T3R5XXG	9	12	45 ~ 65	150	3.5
JMV0402S180T151XXG	13	18	45 ~ 65	150	3.5
JMV0402S260T040XXG	19	26	45 ~ 65	145	4
JMV0603S120T400XXG	9	12	25 ~ 40	110	40
JMV0603S120T3R5XXG	9	12	45 ~ 65	150	3.5
JMV0603S260T040XXG	19	26	45 ~ 65	145	4

	Working Voltage		Varistor Voltage	Clamping Voltage	Capacitance	Peak Current	Transient Energy
Symbol	V_{RMS}	V_{DC}	V_V	V_C	C_P	i_{max}	W_{max}
Units	Volts	Volts (Max.)	Volts	Volts (Max.)	pF (Typical)	Amps (Max.)	Joules (Max.)
Test Condition		< 10 μ A	1mA DC	1A @ 8/20 μ s	1KHz	8/20 μ s	10/1000 μ s
JMV0805S5R5T501XXG	4	5.5	7.8 ~ 12	22	500	80	0.1
JMV0805S090T421XXG	6	9	10.8 ~ 18	30	420	80	0.2
JMV0805S110T361XXG	8	11	14 ~ 20	32	360	100	0.3
JMV0805S140T401XXG	11	14	17.2 ~ 21	38	400	100	0.1
JMV0805S160T401XXG	14	16	22 ~ 28	46	400	120	0.3
JMV0805S180T351XXG	14	18	19.8 ~ 25.2	44	350	120	0.3
JMV0805S220T101XXG	17	22	25 ~ 34	54	100	30	0.1
JMV0805S220T401XXG	17	22	24.3 ~ 30.7	50	400	120	0.3
JMV0805S260T221XXG	20	26	29.7 ~ 37.3	56	220	100	0.4
JMV0805S310T251XXG	25	31	35.1 ~ 43.9	71	250	100	0.3
JMV0805S380T201XXG	30	38	42.3 ~ 52.7	81	200	100	0.3
JMV0805S450T171XXG	35	45	55 ~ 61	93	170	80	0.1

	Working Voltage		Varistor Voltage	Clamping voltage	Capacitance	Peak Current	Transient Energy
Symbol	V_{RMS}	V_{DC}	V_V	V_C	C_p	i_{max}	W_{max}
Units	Volts	Volts (Max.)	Volts	Volts (Max.)	pF (Typical)	Amps (Max.)	Joules (Max.)
Test Condition		< 50 μ A	1mA DC	1A @ 8/20 μ s	1KHz	8/20 μ s	10/1000 μ s
JMV1206S5R6T152XXR	4	5.6	7.0~10.0	22.0	1500	150	1.0
JMV1206S120T801XXR	9	12.0	14.0~18.3	34.0	800	150	0.6
JMV1206S140T401XXR	10	14.0	16.2~19.8	37.0	400	100	0.3
JMV1206S140T801XXR	10	14.0	16.2~19.8	37.0	800	200	0.5
JMV1206S160T132XXR	12	16.0	19.8~24.2	40.0	1300	200	1.0
JMV1206S180T132XXR	13	18.0	21.6~26.0	48.0	1300	200	1.0
JMV1206S180T901XXR	13	18.0	21.6~26.0	48.0	900	100	0.3
JMV1206S260T901XXR	19	26.0	31.0~38.0	62.0	900	200	1.0
JMV1206S300T201XXR	22	30.0	37.0~46.0	73.0	200	100	0.3
JMV1206S300T401XXR	22	30.0	37.0~46.0	73.0	400	100	0.3
JMV1206S300T551XXR	22	30.0	37.0~46.0	73.0	550	200	1.0
JMV1206S330T551XXR	24	33.0	39.0~47.0	75.0	550	180	1.0
JMV1206S380T501XXR	27	38.0	42.3~51.7	88.0	500	200	1.1
JMV1206S450T551XXR	32	45.0	50.4~61.6	95.0	550	180	0.8
JMV1206S480T251XXR	34	48.0	55.8~68.2	100.0	250	100	0.8
JMV1206S560T101XXR	40	56.0	61.0~77.0	120.0	100	100	0.3
JMV1206S560T381XXR	40	56.0	61.0~77.0	120.0	380	180	1.0
JMV1206S650T241XXR	46	65.0	73.8~90.2	135.0	240	100	0.6

	Working Voltage		Varistor Voltage	Clamping voltage	Capacitance	Peak Current
Symbol	V_{RMS}	V_{DC}	V_V	V_C	C_p	i_{max}
Units	Volts	Volts (Max.)	Volts	Volts (Max.)	pF (Typical)	Amps (Max.)
Test Condition		< 50 μ A	1mA DC	2.5A @ 8/20 μ s	1KHz	8/20 μ s
JMV1210S5R6T502XXR	4	5.6	7.0~10.0	22.0	5000	250
JMV1210S180T202XXR	13	18.0	21.6~26.0	48.0	2000	400
JMV1210S220T182XXR	16	22.0	24.3~29.7	52.0	1800	400
JMV1210S260T112XXR	19	26.0	31.0~38.0	62.0	1100	250
JMV1210S260T152XXR	19	26.0	31.0~38.0	62.0	1500	400
JMV1210S300T901XXR	22	30.0	37.0~46.0	77.0	900	250
JMV1210S300T122XXR	22	30.0	37.0~46.0	77.0	1200	400
JMV1210S450T951XXR	32	45.0	50.4~61.6	95.0	950	250

	Working Voltage		Varistor Voltage	Clamping voltage	Capacitance	Peak Current
Symbol	V_{RMS}	V_{DC}	V_V	V_C	C_p	i_{max}
Units	Volts	Volts (Max.)	Volts	Volts (Max.)	pF (Typical)	Amps (Max.)
Test Condition		< 50 μ A	1mA DC	5A @ 8/20 μ s	1KHz	8/20 μ s
JMV1812S180T452XXR	13	18.0	21.6~26.0	48.0	4500	800
JMV1812S220T352XXR	16	22.0	24.3~29.7	52.0	3500	500
JMV1812S220T402XXR	16	22.0	24.3~29.7	52.0	4000	800
JMV1812S260T282XXR	19	26.0	31.0~38.0	65.0	2800	500
JMV1812S260T302XXR	19	26.0	31.0~38.0	65.0	3000	800
JMV1812S300T252XXR	22	30.0	37.0~46.0	78.0	2500	800
JMV1812S380T202XXR	27	38.0	42.3~51.7	88.0	2000	800

	Working Voltage		Varistor Voltage	Clamping voltage	Capacitance	Peak Current
Symbol	V_{RMS}	V_{DC}	V_V	V_C	C_p	i_{max}
Units	Volts	Volts (Max.)	Volts	Volts (Max.)	pF (Typical)	Amps (Max.)
Test Condition		< 50 μ A	1mA DC	10A @ 8/20 μ s	1KHz	8/20 μ s
JMV2220S5R6T203XXR	4	5.6	7.0~10.0	19.0	20000	1200
JMV2220S180T153XXR	13	18.0	22.0~27.0	56.0	15000	1200
JMV2220S300T502XXR	22	30.0	37.0~46.0	85.0	5000	1200
JMV2220S380T402XXR	27	38.0	42.3~51.7	88.0	4000	1200

JMV-C Series

FEATURES

- Lead free type
- SMD type zinc oxide based ceramic chip
- Quick response time (<1ns)
- Low clamping voltage
- Meet IEC 61000-4-2 standard
- Low capacitance can meet high speed signal transient voltage protection
- Compact size for EIA 0402 / 0603

APPLICATIONS

- Low Capacitance Product Applications for High Speed I/O port such as HDMI, DVI, USB, and IEEE1394 etc.
- Normal capacitance product applications for I/O Port such as RS232, USB, PS2, VGA, Audio on Mother Board and Notebook, Set-Top Box, MP3 Players, DVD Players, and Docking System etc.

EXPLANATION OF PART NUMBER

JMV	0402	C	5R5	T	050	XXG
①	②	③	④	⑤	⑥	⑦
① Joyin Multilayer Varistor				⑤ Tape on reel		
② Chip size				⑥ Optional Suffix		
③ ESD Protection Only				⑦ Internal ID		
④ Max DC working voltage						

DIMENSION

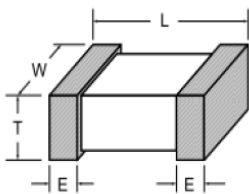

unit:mm

Size(EIA)	L	W	T	E
0402	1.00±0.10	0.50±0.10	0.34±0.10	0.20±0.15
0603	1.60±0.10	0.85±0.15	0.51±0.05	0.30±0.20

SOLDER LAND INFORMATION

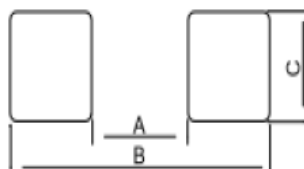

unit:mm

Size(EIA)	A	B	C
0402	0.50	1.70	0.50
0603	0.50	2.50	0.76

STANDARD PACKING

Size (EIA)	0402	0603
Quantity (pcs/reel)	10,000	4,000

SPECIFICATION

	Working Voltage	Varistor Voltage	Clamping Voltage	Capacitance
Symbol	V_{DC}	V_V	V_C	C_p
Units	Volts (Max.)	Volts	Volts (Max.)	pF
Test Condition	< 10 μ A	1mA DC	1A @ 8/20 μ s	1MHz
JMV0402C180T0R5XXG	18	90 ~ 120	250*	0.5
JMV0402C180T010XXG	18	46 ~ 60	110*	1.0
JMV0402C180T030XXG	18	22 ~ 34	58	3.0
JMV0402C180T100XXG	18	22 ~ 34	58	10
JMV0402C180T220XXG	18	22 ~ 34	58	22
JMV0402C180T900XXG	18	22 ~ 34	58	90
JMV0402C5R5T030XXG	5.5	46 ~ 60	105	3.0
JMV0402C5R5T050XXG	5.5	7.6 ~ 12	25	5.0
JMV0402C5R5T220XXG	5.5	7.6 ~ 12	25	22
JMV0402C5R5T101XXG	5.5	7.6 ~ 12	25	100
JMV0402C5R5T221XXG	5.5	7.6 ~ 12	25	220
JMV0402C090T050XXG	9	11 ~ 17	35	5.0
JMV0402C090T220XXG	9	11 ~ 17	35	22
JMV0402C260T050XXG	26	46 ~ 60	110	5.0
JMV0402C420T030XXG	42	46 ~ 75	135	3.0

	Working Voltage	Varistor Voltage	Clamping Voltage	Capacitance
Symbol	V_{DC}	V_V	V_C	C_p
Units	Volts (Max.)	Volts	Volts (Max.)	pF
Test Condition	< 10 μ A	1mA DC	1A @ 8/20 μ s	1MHz
JMV0603C180T0R5XXG	18	90 ~ 120	250*	0.5
JMV0603C180T010XXG	18	46 ~ 60	110*	1.0
JMV0603C180T030XXG	18	22 ~ 34	58	3.0
JMV0603C180T030-1G	18	46 ~ 60	110	3.0
JMV0603C180T101XXG	18	22 ~ 34	58	100
JMV0603C180T221XXG	18	22 ~ 34	58	220
JMV0603C5R5T050XXG	5.5	7.6 ~ 12	25	5.0
JMV0603C5R5T220XXG	5.5	7.6 ~ 12	25	22
JMV0603C090T050XXG	9	11 ~ 17	35	5.0
JMV0603C090T220XXG	9	11 ~ 17	35	22
JMV0603C420T030XXG	42	46 ~ 75	135	3.0

JMV-E Series

FEATURES

- Dual function for EMI and ESD
- Compact size EIA 0402 / EIA 0603
- ESD protection for IEC61000-4-2 Level 4
- Fixed capacitance suitable for high-speed I/O port transient voltage protection

APPLICATIONS

Motherboard, notebook (RS232, USB, PS2, VGA and Audio), Set-Top Box, MP3 Players, DVD Players, and docking system, etc.

EXPLANATION OF PART NUMBER

JMV	0402	E	5R5	T	330	XXG
①	②	③	④	⑤	⑥	⑦
① Joyin Multilayer Varistor				⑤ Tape on reel		
② Chip size				⑥ Optional Suffix		
③ ESD Protection Only				⑦ Internal ID		
④ Max DC working voltage						

DIMENSION

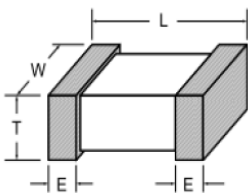

unit:mm

Size(EIA)	L	W	T	E
0402	1.00±0.10	0.50±0.10	0.34±0.10	0.20±0.15
0603	1.60±0.10	0.85±0.15	0.51±0.05	0.30±0.20

SOLDER LAND INFORMATION

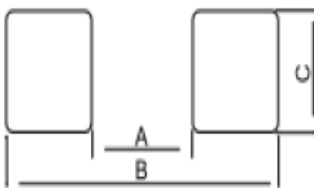

unit:mm

Size(EIA)	A	B	C
0402	0.50	1.70	0.50
0603	0.50	2.50	0.76

STANDARD PACKING

Size (EIA)	0402	0603
Quantity (pcs/reel)	10,000	4,000

SPECIFICATION

	Working Voltage	Varistor Voltage	Clamping Voltage	Capacitance
Symbol	V_{DC}	V_V	V_C	C_P
Units	Volts (Max.)	Volts	Volts (Max.)	pF Tolerance
Test Condition	< 10 μ A	1mA DC	1A @ 8/20 μ s	1MHz
JMV0402E5R5T100XXG	5.5	11 ~ 21	40	10 \pm 30%
JMV0402E5R5T330XXG	5.5	11 ~ 21	38	33 \pm 30%
JMV0402E5R5T470XXG	5.5	9 ~ 19	36	47 \pm 30%
JMV0402E5R5T101XXG	5.5	9 ~ 19	35	100 \pm 30%
JMV0402E5R5T181XXG	5.5	8 ~ 18	34	180 \pm 30%
JMV0402E5R5T331XXG	5.5	8 ~ 18	32	330 \pm 30%

	Working Voltage	Varistor Voltage	Clamping Voltage	Capacitance
Symbol	V_{DC}	V_V	V_C	C_P
Units	Volts (Max.)	Volts	Volts (Max.)	pF Tolerance
Test Condition	< 10 μ A	1mA DC	1A @ 8/20 μ s	1MHz
JMV0603E5R5T100XXG	5.5	11 ~ 21	40	10 \pm 30%
JMV0603E5R5T330XXG	5.5	11 ~ 21	38	33 \pm 30%
JMV0603E5R5T470XXG	5.5	9 ~ 19	37	47 \pm 30%
JMV0603E5R5T101XXG	5.5	9 ~ 19	36	100 \pm 30%
JMV0603E5R5T331XXG	5.5	8 ~ 18	32	330 \pm 30%
JMV0603E5R5T102XXG	5.5	8 ~ 18	30	1000 \pm 30%
JMV0603E120T220XXG	12	15 ~ 25	46	22 \pm 30%
JMV0603E120T151XXG	12	15 ~ 25	44	150 \pm 30%
JMV0603E120T331XXG	12	15 ~ 25	42	330 \pm 30%

JMV-N Series

FEATURES

- RoHS compliant
- Meet IEC61000-4-5 standard (Pass 10/700μs 40Ω surge 4~8KV test)
- SMD type zinc oxide based ceramic chip
- Insulator over coat keeps excellent low and stable leakage current
- Quick response time (<0.5ns)
- High transient current capability
- High reliability
- Compact size for EIA1210

APPLICATIONS

Protection against high working voltage and Network applications related transient overvoltage.

EXPLANATION OF PART NUMBER

JMV	1210	N	600	T	602	AXG
①	②	③	④	⑤	⑥	⑦
① Joyin Multilayer Varistor			⑤ Tape on reel			
② Chip size			⑥ Surge voltage			
③ Networking series			⑦ Internal ID			
④ Max DC working voltage						

DIMENSION

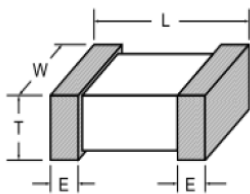

unit:mm

Size(EIA)	L	W	T	E
1210	3.20±0.30	2.50±0.25	1.7 max	0.50±0.25

SOLDER LAND INFORMATION

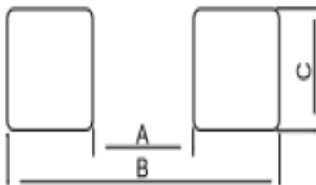

unit:mm

Size(EIA)	A	B	C
1210	2.20	4.50	2.80

STANDARD PACKING

Size (EIA)	1210
Quantity (pcs/reel)	2,000

SPECIFICATION

Symbol	Working Voltage		Varistor Voltage	Clamping Voltage	Capacitance	Peak Current
	V_{RMS}	V_{DC}	V_V	V_C	C_P	i_{max}
Units	Volts (Max.)	Volts (Max.)	Volts	Volts (Max.)	pF (Typical)	Amps (Max.)
Test Condition			1mA DC	2.5A @ 8/20 μ s	1KHz	8/20 μ s
JMV1210N240T602AXG	17	24	27~34	50	5000	2000
JMV1210N380T402AXG	25	38	41~51	70	2400	1500
JMV1210N380T602AXG	25	38	41~51	70	2500	1500
JMV1210N600T402AXG	48	60	69~83	115	1300	1200
JMV1210N600T602AXG	48	60	69~83	115	1350	1200
JMV1210N600T802AXG	48	60	69~83	115	1400	1200
JMV1210N650T602AXG	50	65	73~91	120	900	900

V_{RMS} – Maximum AC operating voltage the varistor can maintain and not exceed 15 μ A leakage current.

V_{DC} – Maximum DC operating voltage the varistor can maintain and not exceed 15 μ A leakage current.

V_V – Voltage across the device measured at 1mA DC current. Equivalent to V_b , "Breakdown Voltage".

V_C – Maximum peak voltage across the varistor measured at 8/20 μ s waveform and 2.5A pulse current.

C_P – Device capacitance measured with zero volt bias 1Vrms.

i_{max} – Maximum peak current which may be applied with 8/20 μ s waveform without device failure.

JMV-B Series

FEATURES

- SMD type zinc oxide based ceramic chip
- Lead free plating termination provided good solderability characteristic
- Insulator over coat keeps excellent low and stable leakage current
- Quick response time (<1ns)
- Low clamping voltage
- High transient current capability (Peak surge current : 1.5KA~4.5KA)
- High reliability
- Meet IEC 61000-4-5 standard
- Compact size for EIA2220

APPLICATIONS

Suitable for base station, Power Line and Low Frequency single line over voltage protect.

EXPLANATION OF PART NUMBER

JMV	2220	B	101	K	452	—XG
①	②	③	④	⑤	⑥	⑦
① Joyin Multilayer Varistor			⑤ Breakdown Voltage Tolerance			
② Chip size			⑥ Surge Current			
③ Base station series			⑦ Internal ID			
④ Breakdown Voltage						

DIMENSION

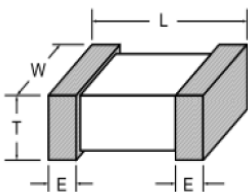

unit:mm

Size(EIA)	L	W	T	E
2220	5.70±0.4	5.20±0.4	4.0 Max.	1.4 Max.

SOLDER LAND INFORMATION

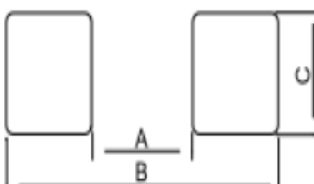

unit:mm

Size(EIA)	A	B	C
2220	4.20	7.20	5.50

STANDARD PACKING

Size (EIA)	2220
Quantity (pcs/reel)	2,000

SPECIFICATION

Symbol	Working Voltage		Varistor Voltage	Clamping Voltage	Capacitance	Peak Current
	V_{RMS}	V_{DC}	V_V	V_C	C_P	i_{max}
Units	Volts (Max.)	Volts (Max.)	Volts	Volts (Max.)	pF (Typical)	Amps (Max.)
Test Condition			1mA DC	8/20 μ s	1KHz	8/20 μ s
JMV2220B250K152-XG	14	16	21.4~27.8	55	8300	1500
JMV2220B250K402-XG	14	16	21.4~27.9	55	19000	4000
JMV2220B820K452-XG	50	65	73.8~90.2	140	6500	4500

V_{RMS} – Maximum AC operating voltage the varistor can maintain and not exceed 50 μ A leakage current

V_{DC} – Maximum DC operating voltage the varistor can maintain and not exceed 50 μ A leakage current

V_V – Voltage across the device measured at 1mA DC current. Equivalent to V_b , “Breakdown Voltage”.

V_C – Maximum peak voltage across the varistor measured at 8/20 μ s waveform

C_P – Device capacitance measured with zero volt bias 1Vrms.

i_{max} – Maximum peak current which may be applied with 8/20 μ s waveform without device failure

8/20 μ s : Calibration method by short circuit

Reliability and Test Condition

For General Products

Test item	Test condition	Reference
Resistance to Solder Heat	<ol style="list-style-type: none"> 1. Solder temperature : $260 \pm 5^{\circ}\text{C}$. 2. Flux : Rosin. 3. DIP time : 10 ± 1 sec. 	MIL-STD-202 Method 210F
Temperature Cycle	<ol style="list-style-type: none"> 1. Temperature: $-40^{\circ}\text{C}/85^{\circ}\text{C}$ For 30 minutes each temperature. 2. Cycle: 100 cycles. 3. Measurement: At room temperature 24 hours after test completion. 	JESD22 MIL STD 202-107
High Temperature Life	<ol style="list-style-type: none"> 1. Temperature: $85 \pm 2^{\circ}\text{C}$. 2. Testing time: 1000 hrs. 3. Applied rated source. 4. Measurement: At room temperature 24 hours after test completion. 	MIL-STD-202 Method 108
Bias Humidity Test	<ol style="list-style-type: none"> 1. Temperature: $40 \pm 2^{\circ}\text{C}$. 2. Humidity: 90% RH. 3. Applied rated source. 4. Testing time: 1000 hrs. 5. Measurement: At room temperature 24 hours after test completion. 	MIL-STD-202 Method 103
Solderability	<ol style="list-style-type: none"> 1. 8 hours \pm 15 min. steam conditioning 2. Solder temperature : $245 \pm 5^{\circ}\text{C}$. 3. Flux : Rosin. 4. DIP time : 5 ± 1 sec. 	J-STD-002
Resistance to Solvent	<ol style="list-style-type: none"> 1. Immerse the chips in the IPA solution with ultrasonic. 2. Testing time: 5 min. 3. Measurement: At room temperature 1 hours after test completion. 	MIL-STD-202 Method 215
Moisture Sensitivity	<ol style="list-style-type: none"> 1. Temperature: $85 \pm 2^{\circ}\text{C}$. 2. Humidity: 85% RH. 3. Testing time: 168 hrs. 	J-STD-020

PACKAGING SPECIFICATIONS

Carrier Tape Specifications

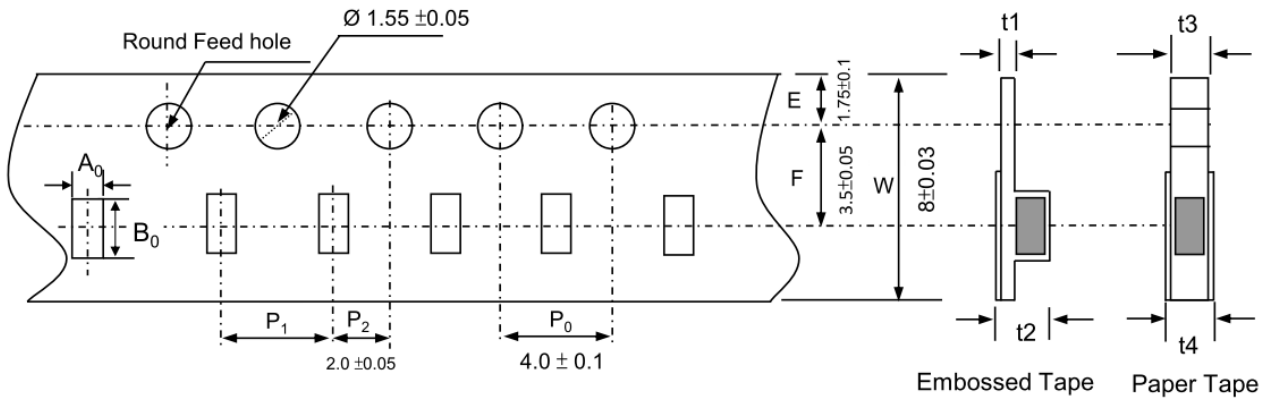

Dimensions

Unit in mm

SIZE	$A_0 \pm 0.1$	$B_0 \pm 0.1$	$P_1 \pm 0.1$	t_3 / t_4	$t_1 \pm 0.05$	$t_2 \pm 0.10$
0201	0.36	0.70	2	$t_4 \leq 0.5$		
0402	0.65	1.15	2	1.0max / 1.1max		
0603	1.10	1.90	4	1.0max / 1.1max		
0805	1.50	2.35	4	1.0max / 1.1max		
1206	1.88	3.50	4		0.22	1.27
1210	2.77	3.42	4		0.24	1.85

Carrier Tape Specifications

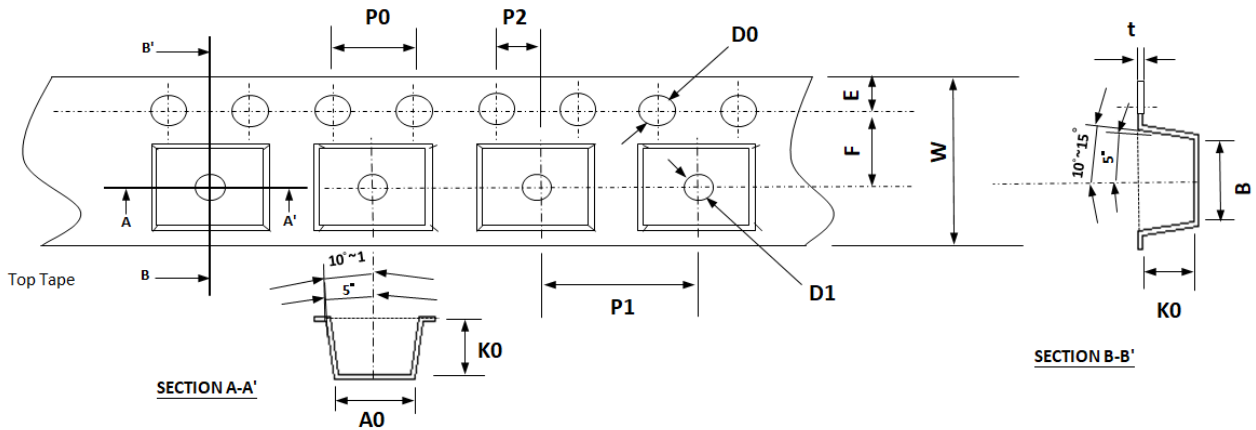

Dimensions of Embossed Tape

Unit in mm

SIZE	W	E	F	D0	D1	P0	P2	P0 * 10
1812	12.0 ± 0.10	1.75 ± 0.10	5.50 ± 0.05	1.55 ± 0.10	1.50 ± 0.10	4.0 ± 0.10	2.0 ± 0.05	40.0 ± 0.20
	12.0 ± 0.15	1.75 ± 0.10	5.50 ± 0.10	1.55 ± 0.10	1.55 ± 0.10	4.0 ± 0.10	2.0 ± 0.10	40.0 ± 0.20
	12.0 ± 0.30	1.75 ± 0.10	5.50 ± 0.05	1.50 ± 0.10	1.50 ± 0.10	4.0 ± 0.10	2.0 ± 0.05	40.0 ± 0.20
2220	A0	B	K0	P1	t			
2220B9	3.66 ± 0.10	4.95 ± 0.10	1.85 ± 0.10	8.0 ± 0.10	0.24 ± 0.05			
	5.30 ± 0.10	6.35 ± 0.10	1.80 ± 0.10	8.0 ± 0.10	0.25 ± 0.05			
	5.45 ± 0.05	5.95 ± 0.05	3.20 ± 0.10	8.0 ± 0.10	0.40 ± 0.05			

Reel Specifications

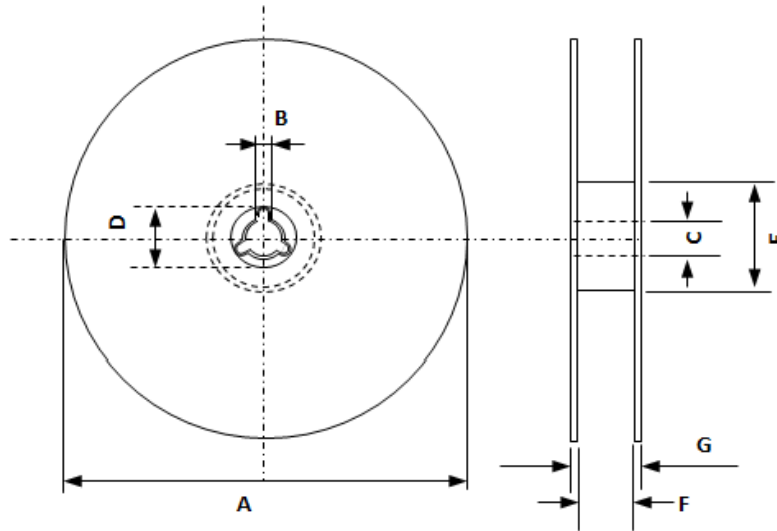

Unit in mm

SIZE	A	B	C	D	E	F	G	Quantity Reel (pcs)
0201	178 ± 2.0	2.0 ± 0.5	13.0 ± 0.5	21.0 ± 0.8	62.0 ± 1.5	9.0 ± 0.5	13.0 ± 1.0	15,000
0402	178 ± 2.0	2.0 ± 0.5	13.0 ± 0.5	21.0 ± 0.8	62.0 ± 1.5	9.0 ± 0.5	13.0 ± 1.0	10,000
0603	178 ± 2.0	2.0 ± 0.5	13.0 ± 0.5	21.0 ± 0.8	62.0 ± 1.5	9.0 ± 0.5	13.0 ± 1.0	4,000
0805	178 ± 2.0	2.0 ± 0.5	13.0 ± 0.5	21.0 ± 0.8	62.0 ± 1.5	9.0 ± 0.5	13.0 ± 1.0	4,000
1206	178 ± 1.0	2.4 ± 0.5	13.3 ± 0.5		60.0 ± 1.0	9.5 ± 0.5	11.7 ± 0.5	3,000
1210	178 ± 1.0	2.4 ± 0.5	13.3 ± 0.5		60.0 ± 1.0	9.5 ± 0.5	11.7 ± 0.5	2,000
1812	178 ± 1.0	2.4 ± 0.5	13.5 ± 0.5		60.0 ± 1.0	13.7 ± 0.5	16.1 ± 0.5	1,000
2220	178 ± 1.0	2.4 ± 0.5	13.5 ± 0.5		60.0 ± 1.0	13.7 ± 0.5	16.1 ± 0.5	1,000
2220 B9	330 ± 2.0	2.3 ± 0.2	13.5 ± 0.2		99.0 ± 1.5	16.5 ± 0.5	18.7 ± 0.5	2,000